

NEW



WHEELED LOADING SHOVEL | 457

Gross engine power: 258 hp (193 kW) Operating weight: 43210 – 54233 lb (19.6 – 24.6 t)
Full turn tipping load: 30181 lb (13,690 kg) Standard shovel capacity: 4.6 yd³ (3.5m³)



We started with a simple yet expansive brief: to give you the world's very best wheeled loading shovel. The all-new JCB 457 is the result, and we think you'll agree that it's a success. It represents a quantum leap in power, productivity, efficiency, comfort, ease of use and safety. As such, it's an investment that's sure to prove a great business decision for you and your business.

epic.





STRENGTH.

THE NEW JCB 457 HAS BEEN BUILT USING ONLY THE MOST ADVANCED PRODUCTION TECHNIQUES AND PREMIUM COMPONENTRY FOR SUPERIOR STRUCTURAL STRENGTH. IT'S BEEN TESTED TO THE LIMIT ON SITES ALL OVER THE WORLD TO MAKE SURE THAT, WHEREVER YOU'RE OPERATING, YOU'LL MAINTAIN TOTAL PRODUCTIVITY.

Designed to work hard.

1 Your new JCB 457 will have been developed using finite element analysis and rig testing of up to 1 million cycles to ensure superior structural strength and durability. For further peace of mind, cold cell testing guarantees starting performance down to -4°F (-20°C).

2 High tolerances and accurate location of pins and bushes are guaranteed with JCB's precision machining techniques.

3 You can specify a 457 for heavy-duty applications like waste or corrosive material handling.

4 State-of-the-art manufacturing processes like robot machining, precision paint technology and innovative assembly techniques help to achieve the very highest levels of build quality.

The new MTU engine has all the grunt you need for day-to-day operation, together with a rugged construction that can cope with the sort of sudden hard load change when switching between tasks.



Protecting ancillaries.

5 A solid cast rear counterweight protects your 457's back end – including the rear lights and cooling pack – from damage.

Well articulated.

6 Hoses are neatly routed and clamped through the articulation joint, well away from any pinch points.

7 The articulation joint has a heavy-duty center pin and oversized bush, as well as twin taper roller bearings on the top box joints. This setup can tolerate both vertical and horizontal loadings for durability and rigidity.

The 457's articulation joint has a heavy-duty box section that's much stronger than a single plate with a boss. Its steering rams are positioned high up and well protected from possible impact and site damage.



5



6

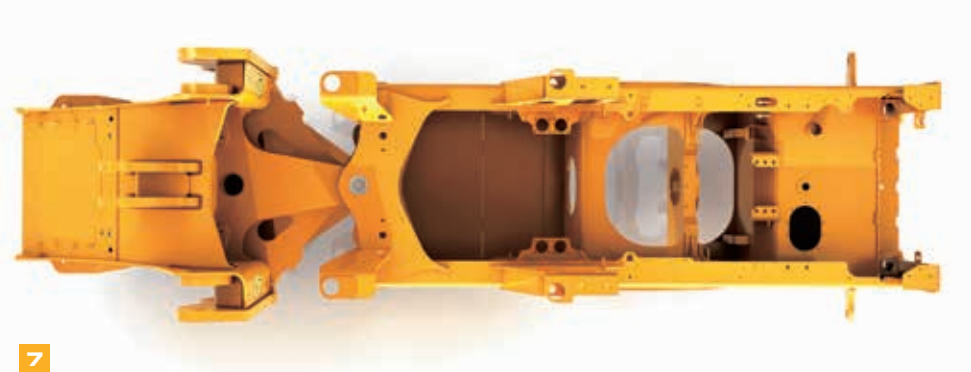

7

SPEED.

TIME IS OF THE ESSENCE ON ANY WORKSITE SO THE NEW JCB 457 IS DESIGNED TO PROVIDE THE FASTEST CYCLE TIMES IN THE BUSINESS. POWERFUL TWIN HYDRAULIC PUMPS, A LOAD SENSING VALVE BLOCK AND OPTIONAL 5-SPEED TRANSMISSION WITH TORQUE LOCK-UP PROVIDE SPEED, ACCURACY AND PRODUCTIVITY IN ABUNDANCE.

Powering it all.

1 The MTU 6R1000 470 cubic inch (7.7 Liter) engine fitted to the new JCB 457 produces a substantial 258hp (193kW) of power, not to mention 848 lb-ft (1150Nm) of torque (6% more than our outgoing model). What's more, it produces all of this at low revs for an incredibly responsive operating experience.



Loading productivity.

2 Powerful twin variable displacement piston pump hydraulics can circulate a massive 81 gallons/min (323 l/min) for fast cycle times and excellent multifunctioning capability.

3 Choose the optional JCB quickhitch and you'll find attachment changing is quick and efficient.

4 Specify your perfect loader arm: Z-bar linkage (ZX) for high breakout applications or high torque (HT) for parallel lifting and multi attachment work.



There's no need to worry about wasting time and money replacing a diesel particulate filter (DPF) on your 457; its MTU engine meets Tier 4 Final legislation using only exhaust gas recirculation (EGR) and selective catalytic reduction (SCR) methods. This setup also improves fuel economy.



The innovative electronic management system can perform progressive clutch cut-off for efficient, productive loader control. This feature governs tractive effort via the transmission, diverting maximum power to the loader hydraulics whilst reducing service brake wear and fuel consumption.

Loading productivity (continued).

5 High lift and super high lift options equip your 457 for applications involving high loading heights.

6 With maximum breakout forces of 38667 lbs (172 kN), this wheel loader has the power to carry out extremely arduous loading jobs.

Drivetrain productivity.

7 A smooth 4-speed transmission is fitted as standard, while an optional 5-speed unit makes operation even more slick, with closer gear ratios for improved acceleration, hill climbing and roading performance. The 5-speed gearbox also has torque convertor lock-up to eliminate losses, allowing faster cycle times and improved efficiency.

8 Tailor a 457 to any application with a range of axle options:

> Open differentials are ideal for hard standing ground conditions.

> A limited slip differential is perfect for soft, muddy terrain with reduced traction.

> Open differentials with an automatic locking front diff provide excellent traction in varied ground conditions.

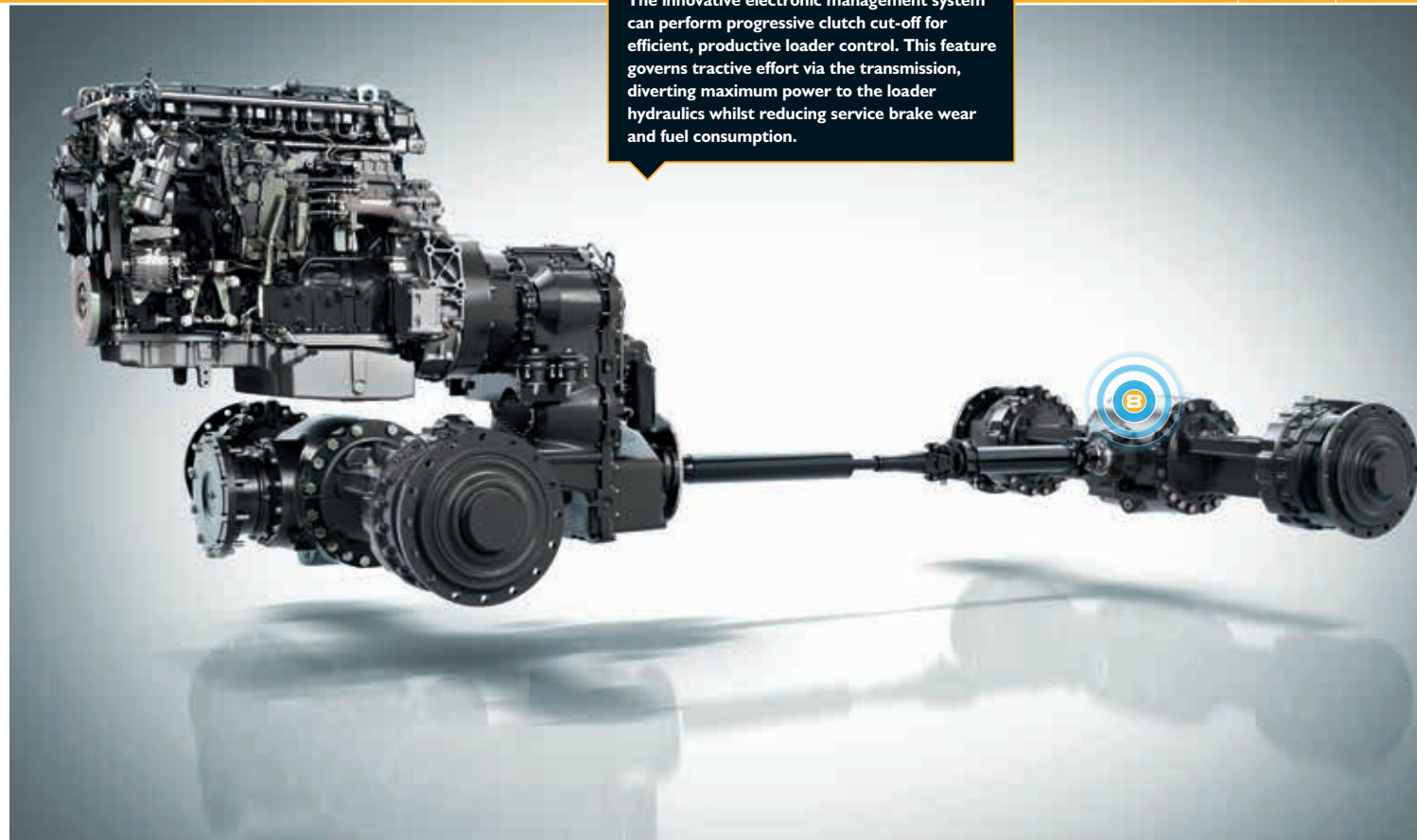

POWER.

POWER WITHOUT COMPROMISE HAS LONG BEEN THE ESSENCE OF ANY LARGE WHEELED LOADING SHOVEL, AND THE NEW JCB 457 TAKES THIS ETHOS TO ANOTHER LEVEL. ITS CUTTING EDGE TIER 4 FINAL MTU ENGINE BOASTS PLENTY OF POWER, WHILE THE EFFICIENT, SMOOTH ZF DRIVELINE AND LOW FUEL CONSUMPTION HELP TO MAKE YOUR DECISION EVEN EASIER.

Driving efficiency.

1 The new JCB 457's MTU engine offers you huge levels of low-end torque and maintains it over a wide engine speed range. By using lightweight materials like cast aluminium and synthetics, you can also expect an excellent power-to-weight ratio.

To save on fuel, the engine idle shutdown feature can safely apply the brakes and turn your machine off after a programmable amount of time.

2 A hydraulic cooling fan automatically reacts to ambient temperature and adjusts the 457's fan speed to optimize cooling and reduce fuel consumption. This also lowers noise on your site.

3 Opt for the torque lock up 5-speed transmission and you'll get 100% efficiency in gears 2 through 5, as well as closer gear ratios to keep engine speeds down. The end result is improved fuel economy.



No DPF means unnecessary additional fuel piping is eliminated as is the potentially dangerous temperatures involved in regeneration. The fuel that would have been needed to restore your DPF can be used instead for actual productive work.

JCB's innovative variable displacement pumps feed a load-sensing valve block which only consumes power on demand, providing precise, efficient loader control.

Driving efficiency (continued).

- 4** Wheel speed braking means the brakes on the new 457 rotate at the same speed as the wheels for heat and drag reduction, as well as improved fuel economy.
- 5** Unloaded spool valves in the valve block allow the arms to lower under gravitation – not hydraulic – force; this reduces fuel consumption still further.
- 6** Patented JCB Smoothride load suspension limits shock loadings on your machine. You therefore enjoy reduced material spillage and structural stress, as well as increased operator comfort.
- 7** A choice of 3 or 4-spool hydraulics gives you the scope for invaluable extra versatility.
- 8** Selectable loader arm detents let operators control loader arm height limitations, return to dig settings and float functions, improving safety and productivity.



COMMANDPLUS.

THE NEW 457 BRINGS THE DAWN OF A NEW ERA IN CAB DESIGN: JCB COMMAND PLUS. THIS UNIQUE APPROACH TO ERGONOMICS IS THE RESULT OF A RADICAL RETHINK AND A RIGOROUS RESEARCH PROGRAMME. EXPECT BEST-IN-CLASS COMFORT, VISIBILITY, ERGONOMICS AND QUIETNESS.

See the difference.

1 You'll immediately notice the totally redesigned ROPS structure; this has allowed the A pillars to be moved to the same width as the rear of the cab, providing a larger interior with a superb panoramic front windshield. All switches and auxiliary controls are now located on the right-hand A-pillar for easier access.

2 Using the JCB 457's simple, dedicated menu interface is easily done with an intuitive optional rotary controller.

3 Controlling the loader is now easier than ever – all of the controls are seat-mounted, even going as far as to move with the seat suspension.

Select the control system that's best for your operators; we offer single lever joystick or multi-lever configurations, both fully electro-hydraulic.

4 There are two full colour LCD screens to navigate your 457's operating menus, with one doubling as a screen for the rear view camera (optional).



For maximum visibility and minimal replacement costs, we've revised the front screen to incorporate only flat panes where possible.



The noise level in the cab is an incredibly low 68dB(a): so quiet you can hardly hear the engine running.

5 As standard, the new JCB 457 is equipped with heated external mirrors that can be electronically adjusted from inside the cab.



6 An all-new air venting system boasts nine demisting vents and six operator vents to maintain visibility and operator comfort at all times. It also operates at a reduced noise level.



7 After extensive research into operator ergonomics, we've devised the Command Driving Position, which boasts the very optimal control layout for a multitude of different driver shapes and sizes.

8 A set and forget feature means that your preferred steering wheel position is stored and can be instantly returned to, even after you've folded the wheel away for easier operator access.

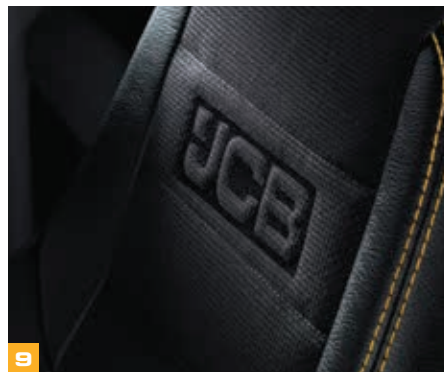

9 Several seating options are available: there's a premium quality hard-wearing half leather seat, a heated seat or even a cooled one if you plan to operate your JCB 457 in warmer climates.

Air conditioning is a standard feature and there's also the option of automatic climate control to create perfect working temperatures.

With a dedicated media port on board, you can be assured of superb connectivity for all your electronic devices.



SERVICE.

MAXIMIZING YOUR FLEET'S UPTIME IS OUR NUMBER ONE PRIORITY, AND WE'VE CERTAINLY NOT HELD BACK ON THE NEW JCB 457. A UNIQUE ONE-PIECE HOOD, EASY GROUND LEVEL ACCESS TO KEY COMPONENTS, LIVELINK TELEMATICS AND WORLD-CLASS AFTERCARE ALL COME AS STANDARD, WITH TAILORED SERVICE PACKAGES AVAILABLE TO SUIT.

Routine maintenance.

1 It's easy to get to the engine on a new JCB 457 with a large automatic opening single-piece hood.

2 Accessing the diesel and DEF (Diesel Exhaust Fluid) tanks is similarly straightforward via the lockable grille at the rear of the machine.

Full hydraulic dual circuit braking with multiple oil-immersed discs provides a virtually maintenance-free lifespan.

3 Most Tier 4 Final engines use a costly Diesel Particulate Filter (DPF) that can require replacement at the expense of both money and time. The MTU engine is DPF-free, reducing your servicing and running costs.

4 The standard cooling package is a large single-faced unit so you can be assured of quick, easy and safe cleaning.





Less servicing, more service.

5 Intelligent electronic monitoring keeps you aware of your 457's operating condition, providing real-time alerts that help to safeguard both the machine and its operator.

5 You can check brake, steering and hydraulic system pressures easily with the grouped test ports.

By using exclusively premium components (MTU engine, ZF transmissions and axles, Rexroth pumps and Parker valve blocks), we've built in long service life as standard.

The main fuse board and relays have been repositioned next to the door for easy access.

Select the widecore cooling pack and reversing fan option to ensure superior cooling efficiency in environments with large amounts of debris in the air.

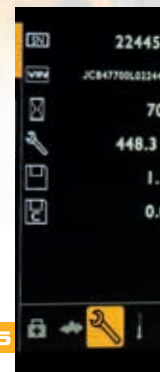

SAFETY.

OPERATORS, SITE PERSONNEL AND YOUR FLEET ARE WELL PROTECTED AT ALL TIMES BY THE NEW JCB 457. GREAT VISIBILITY INSIDE AND OUT, NON-SLIP SURFACES AND EXCELLENT AIR FILTRATION IS JUST THE START.

Safely does it.

- 1** If you plan to use your wheeled loader for quarry work, it's worth specifying the dedicated quarry safety pack, which includes blue flashing reverse lights, a green operator presence beacon, a rear object detection system, and hi-viz exterior chevrons.
 - 2** Access steps are inclined and equally spaced, complemented by well positioned grab handles for three points of contact at all times.
 - 3** On the new JCB 457, you'll find the rear-view mirrors mounted in front of the A-pillars for improved all-round visibility.
- Interior mirrors, heated exterior mirrors and hood mirrors combine to offer excellent views to every corner of your machine.
- 4** Our optional rearward camera displays an unobstructed view from the back of the machine.
 - 5** Superb visibility in dark conditions is guaranteed with JCB's optional LED lighting.





Safely does it (continued).

- 5** The new front fender flaps have been carefully designed and refined to keep forward spray to a minimum. This increases safety and decreases debris build-up.
- 7** The new 457's cab is isolator-mounted, compliant with ROPS/FOPS standards, and positively pressurised against dust. You can choose from fresh air and carbon recirculation filters as well.
- 6** Door hinges are now mounted on the B-pillar; this simple change has created much better access via a larger and wider door aperture. It also means you can access the rear of your loader more safely.
- 8** Engines fitted with a DPF pose a greater fire risk because in regeneration mode, extreme heat can be created. The new 457 doesn't need a DPF, so this is no cause for concern.



LIVELINK, WORK SMARTER.

LIVELINK IS AN INNOVATIVE SOFTWARE SYSTEM THAT LETS YOU MANAGE JCB MACHINES REMOTELY – ONLINE, BY EMAIL OR ON YOUR CELL PHONE. ACCESS EVERYTHING FROM MACHINE ALERTS TO FUEL REPORTS AND HISTORY INFORMATION, WITH ALL DATA STORED AT A SECURE CENTER.

Productivity and cost benefits

By providing information like idle time monitoring and machine fuel consumption, JCB Livelink helps reduce your fuel usage, saving money and improving productivity. Machine location information can help improve efficiency and perhaps even reduce insurance costs.



Maintenance benefits

Manage machine maintenance easily – accurate hours monitoring and service alerts improve maintenance planning, while real-time location data helps you manage your fleet. Critical machine alerts and maintenance history records are also available.



Security benefits

Livelink's real-time geofencing alerts tell you when machines move out of predetermined zones, and real-time curfew alerts inform you of unauthorized usage. Further benefits include real-time location information.



A GREAT BUSINESS DECISION.

WE'LL PROVIDE YOU WITH FIRST CLASS SUPPORT AND ASSISTANCE TO SUIT YOUR EXACT BUSINESS NEEDS RIGHT FROM DAY ONE. SO WHEREVER YOU ARE, YOUR MACHINE WILL ALWAYS PERFORM TO ITS FULL POTENTIAL – ONE OF MANY REASONS WHY STARTING A WORKING RELATIONSHIP WITH JCB IS A GREAT BUSINESS DECISION.

Machine selection

Your JCB dealer has the right technical knowledge and expertise to ensure that you assess all the machine options available to you. This includes rental options and new or used machine sales.

Rebuild and Refurbishment Programme

If your business isn't in a position to buy a brand new machine, then JCB's Rebuild and Refurbishment programme can help you to extend the service life of your current vehicle cost-effectively.

Technical support

All local JCB dealers have instant access to factory expertise and technical support to provide you with the maximum machine uptime. JCB's Global Parts Centres, meanwhile, deliver around 95% of all parts anywhere in the world within 24 hours.

Component monitoring

JCB machines benefit from a sophisticated component monitoring programme that provides preventative maintenance and oil sampling to keep everything working at its optimal level.

Service support

We offer a range of extended warranties, from JCB PremierCover (full comprehensive cover) to JCB PowertrainCover (engine, axles, transmission and hydraulic pump cover). Service agreements, as well as service-only or Repair and Maintenance contracts ensure that we have the up-time of your wheel loader totally covered. Our dealer maintenance specialists around the world charge competitive labor rates, and offer non-obligation quotations as well as fast, efficient repair work.

Finance and Insurance

Finance and Insurance specialists are always on-hand to provide fast, flexible, competitive quotes. Naturally, packages can be tailored to suit your specific business needs.



STATIC DIMENSIONS

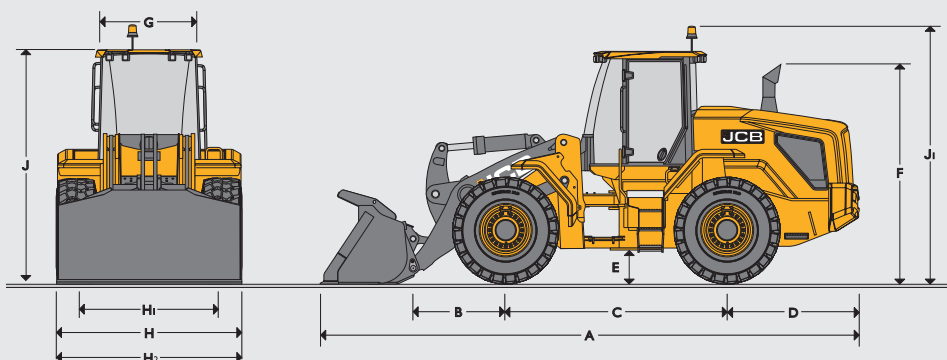

			457 HT	457 HT SHL	457 ZX	457 ZX HL
A	Overall length	ft-in (mm)	27' 11" (8521)	31' 0" (9451)	26' 1" (7961)	27' 1" (8521)
B	Axle to pivot pin	ft-in (mm)	5' 7" (1713)	8' 11" (2727)	5' 4" (1622)	7' 2" (2182)
C	Wheel base	ft-in (mm)	10' 10" (3300)	10' 10" (3300)	10' 10" (3300)	10' 10" (3300)
D	Axle to counterweight face	ft-in (mm)	6' 6" (1971)	6' 6" (1971)	6' 6" (1971)	6' 6" (1971)
E	Minimum ground clearance	ft-in (mm)	1' 7" (473)	1' 7" (473)	1' 7" (473)	1' 7" (473)
F	Height over exhaust	ft-in (mm)	10' 7" (3224)	10' 7" (3224)	10' 7" (3224)	10' 7" (3224)
G	Width over cab roof	ft-in (mm)	5' 3" (1600)	5' 3" (1600)	5' 3" (1600)	5' 3" (1600)
H	Max width over tires	ft-in (mm)	8' 10" (2699)	8' 10" (2699)	8' 10" (2699)	8' 10" (2699)
H1	Wheel track	ft-in (mm)	6' 11" (2100)	6' 11" (2100)	6' 11" (2100)	6' 11" (2100)
H2	Max width over fenders	ft-in (mm)	9' 0" (2735)	9' 0" (2735)	9' 0" (2735)	9' 0" (2735)
J	Height over cab roof and lowered beacon	ft-in (mm)	11' 3" (3433)	11' 3" (3433)	11' 3" (3433)	11' 3" (3433)
J1	Height over raised beacon	ft-in (mm)	12' 5" (3793)	12' 5" (3793)	12' 5" (3793)	12' 5" (3793)
	Front axle weight	lbs (kg)	19491 (8841)	23732 (10765)	19529 (8858)	20782 (9426)
	Rear axle weight	lbs (kg)	25779 (11693)	23541 (10678)	24066 (10916)	23551 (10683)
	Total weight	lbs (kg)	45270 (20534)	24274 (21443)	43594 (19774)	44333 (20109)
	Inside turn radius	ft-in (mm)	10' 5" (3183)	10' 5" (3183)	10' 5" (3183)	10' 5" (3183)
	Maximum turn radius over shovel	ft-in (mm)	21' 9" (6630)	23' 4" (7121)	21' 6" (6554)	22' 3" (6770)
	Maximum turn radius over tire	ft-in (mm)	19' 4" (5883)	19' 4" (5883)	19' 4" (5883)	19' 4" (5883)
	Articulation angle	deg	+/-40	+/-40	+/-40	+/-40

Data based on machine equipped with direct mounted 4.1yd³ (3.1m³) bucket with toe plates and bolt on teeth and 23.5- 25 R25 BKT L3.

TRANSMISSION

		4 speed non-lock up converter		5 speed with lock up converter (optional)			
Type		ZF		ZF			
Model		4WG210		5WG210 with lock-up (unlocked)		5WG210 with lock-up (locked)	
		Forward	Reverse	Forward	Reverse	Forward	Reverse
1	mph (kph)	3.7 (6.0)	4.0 (6.4)	3.9 (6.2)	4.1 (6.6)	3.9 (6.2)	4.1 (6.6)
2	mph (kph)	7.3 (11.8)	7.8 (12.5)	6.9 (11.1)	7.2 (11.6)	7.0 (11.2)	7.3 (11.8)
3	mph (kph)	13.9 (22.4)	14.6 (23.5)	10.4 (16.8)	16.6 (26.7)	10.7 (17.2)	17.4 (28.0)
4	mph (kph)	22.4 (36.1)		15.9 (25.5)		16.5 (26.6)	
5	mph (kph)			23.4 (37.6)		25.2 (40.5)	

ENGINE

Type	MTU	
Model	6R1000	
Capacity	in ³ (litres)	470 (7.7)
Aspiration	Turbocharger	
Cylinders	6	
Max gross power to SAE J1995/ISO 14396	hp (kW) @ 1600rpm	258 (193)
Nett power to ISO 9249	hp (kW) @ 1600rpm	256 (191)
Max torque	lb-ft (Nm) @ 1200 – 1600rpm	848 (1150)
Valves per cylinder	4	
Air cleaner	Intergrated pre-cleaner, scavenged	
Fan drive type	Hydraulic	
Emissions	EPA 40 CFR 89 / Tier 4 Final	

AXLES

Type	Open differential	Limited slip differential	Open differential with auto-locking front
Make and model	ZF MT-L 3095 MK 2 (front and rear)	ZF MT-L 3095 MK 2 (front and rear)	ZF MT-L 3095 MK 2 (front and rear)
Overall axle ratio	23.334:1	23.334:1	23.334:1
Rear axle oscillation	+/-11.5	+/-11.5	+/-11.5
Bias Ratio	12%	30%	100% (when locked)

3 axle options available: Torque proportioning differentials, limited slip differentials or open differentials with automatic locking. All axle options feature wheel speed braking and lower heat build up and longer service life.

ELECTRICAL SYSTEM

System voltage	Amps	24
Alternator output	Amps	100
Battery capacity	Amp hour	2 x 110

Connectors to IP67 standard.

HYDRAULICS

Pump type	Variable displacement	
Pump 1 max. flow	gal/min (l/min)	40.42 (153)
Pump 1 max. pressure	psi (bar)	3191 (220)
Pump 2 max. flow	gal/min (l/min)	40.42 (153)
Pump 2 max. pressure	psi (bar)	2466 (170)

Hydraulic cycle times at full engine

Arms raise (full bucket)	Seconds	5.8
Shovel dump (full bucket)	Seconds	1.2
Arms lower (empty bucket)	Seconds	4.1
Total cycle	Seconds	11.1

Variable displacement piston pump feed and 'load sensing' system providing a fuel efficient and responsive distribution of power as required. Main services are servo actuated from a single lever (joystick) or electronic actuated from a multi lever loader control. Auxiliary circuit controlled via proportional switch on single lever and additional lever on multi lever control. Accumulator back-up is available to control loader in the event of loss of pump pressure.

CAB	In-cab noise level – 68dB(A).
STEERING	Hydraulic power steering.
BRAKES	Hydraulic power braking on all wheels. In-board mounted, oil immersed, multi-plate disc brakes. Parking brake, electro-hydraulic disc type operating on transmission output shaft.

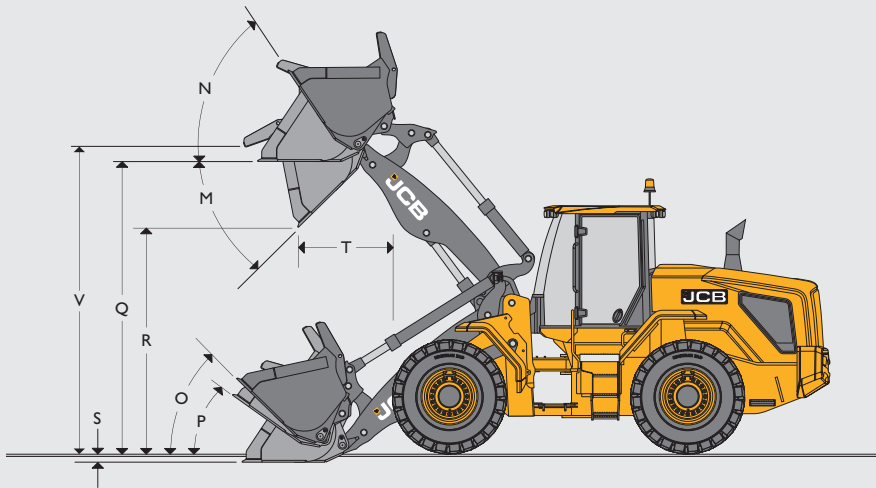

TIRE SIZE – 457 HT

Tire size	Manufacturer	Type	Rating	Op weight lbs (kg)	HT		Dimensions	
					STL lbs (kg)	FTTL lbs (kg)	Vertical in (mm)	Width ft-in (mm)
23.5R25 (radial)	Michelin	XTLA	L2	-26 (-12)	-17 (-8)	-15 (-7)	-0.1 (-2)	-0.1 (-3)
650/65R25 (radial)	Michelin	XLD	L3	-203 (-92)	-138 (-63)	-121 (-55)	-2.2 (-56)	1.4 (35)
23.5R25 (radial)	Goodyear	TL-3A+	L3	714 (324)	487 (221)	429 (195)	0.6 (16)	0.6 (16)
23.5R25 (radial)	Goodyear	RT-3B	L3	388 (176)	264 (120)	234 (106)	0.5 (12)	1.6 (41)
23.5R25 (Crossply)	Goodyear	HRL-3A (20PLY)	L3	-220 (-100)	-149 (-68)	-132 (-60)	0.9 (24)	0.9 (23)
23.5R25 (Crossply)	JCB	SITEMASTER (24PLY)	L3	-203 (-92)	-138 (-63)	-123 (-56)	0.2 (6)	0.0 (1)
23.5R25 (radial)	JCB	EARTHMOVER	L3	353 (160)	240 (109)	212 (96)	0.0 (1)	0.2 (6)
23.5R25 (radial)	Michelin	XLDD2A	L5	1208 (548)	824 (374)	728 (330)	1.1 (27)	0.5 (13)
23.5R25 (radial)	Michelin	XMINED2	L5	1825 (828)	1245 (565)	1100 (499)	1.5 (37)	1.5 (38)
23.5R25 (radial)	Goodyear	RL-5K	L5	1746 (792)	1190 (540)	1052 (477)	0.4 (9)	0.9 (24)
23.5-25 (solid cushion)*	SG Revolution	S2 C2 DWL	-	6887 (3124)	4696 (2130)	4146 (1881)	2.0 (51)	-0.9 (-24)
Heavy-duty counterweight	-	-	-	1706 (774)	3334 (1281)	2824 (1281)	0.0 (0)	0.0 (0)

*Heavy duty counterweight replaced by standard counterweight when solid tires are fitted

LOADER DIMENSIONS – 457 HT

Assumes machine is fitted with Michelin 23.5R25 XHA2 (L3) tires and heavy duty counterweight.

Model	457 HT												
	Shovel mounting	Direct						Quickhitch					
		General purpose						General purpose					
Shovel type	General purpose						General purpose						
Shovel equipment	Tipped teeth		Reversible toeplate		Tipped teeth and toeplate segments		Tipped teeth		Reversible toeplate		Tipped teeth and toeplate segments		
Shovel capacity (SAE heaped)	yd ³ (m ³)	4.1 (3.1)	4.3 (3.3)	4.3 (3.3)	4.6 (3.5)	4.3 (3.3)	4.6 (3.5)	4.1 (3.1)	4.3 (3.3)	4.3 (3.3)	4.6 (3.5)	4.3 (3.3)	4.6 (3.5)
Shovel capacity (struck)	yd ³ (m ³)	3.3 (2.497)	3.5 (2.687)	3.5 (2.687)	3.7 (2.844)	3.5 (2.648)	3.7 (2.844)	3.3 (2.497)	3.5 (2.687)	3.5 (2.648)	3.7 (2.844)	3.5 (2.648)	3.7 (2.844)
Shovel width	ft in (mm)	9' 4" (2837)	9' 4" (2837)	9' 2" (2800)	9' 2" (2800)	9' 4" (2837)	9' 4" (2837)	9' 4" (2837)	9' 4" (2837)	9' 2" (2800)	9' 2" (2800)	9' 4" (2837)	9' 4" (2837)
Shovel weight	lbs (kg)	3349 (1519)	3450 (1565)	3591 (1629)	3693 (1675)	3675 (1667)	3777 (1713)	3144 (1426)	3124 (1417)	3386 (1536)	3486 (1581)	3470 (1574)	3569 (1619)
Maximum material density *	lbs/ft (kg/m ³)	135 (2167)	126 (2022)	126 (2020)	118 (1886)	126 (2014)	118 (1886)	128 (2048)	119 (1911)	119 (1908)	112 (1786)	119 (1902)	111 (1781)
Tipping load straight *	lbs (kg)	35109 (15925)	34887 (15825)	34872 (15817)	34649 (15717)	34790 (15780)	34567 (15679)	33276 (15094)	33072 (15001)	33038 (14986)	32834 (14893)	32956 (14948)	32751 (14856)
Tipping load full turn *	lbs (kg)	29625 (13438)	29419 (13344)	29387 (13330)	29181 (13236)	29305 (13293)	29099 (13199)	27995 (12698)	27806 (12613)	27757 (12590)	27567 (12504)	27674 (12553)	27485 (12467)
Payload *	lbs (kg)	14812 (6719)	14710 (6672)	14694 (6665)	14590 (6618)	14653 (6646)	14549 (6599)	13998 (6349)	13903 (6306)	13878 (6295)	13784 (6252)	13837 (6276)	13742 (6233)
Maximum breakout force	lbf (kN)	36194 (161)	34396 (153)	33721 (150)	32148 (143)	33721 (150)	32148 (143)	32372 (144)	31024 (138)	30349 (135)	29225 (130)	30349 (135)	29225 (130)
M Dump angle maximum	degrees	50 (45)	50 (45)	50 (45)	50 (45)	50 (45)	50 (45)	50 (45)	50 (45)	50 (45)	50 (45)	50 (45)	50 (45)
N Roll back angle full height	degrees	43 (57)	43 (57)	43 (57)	43 (57)	43 (57)	43 (57)	43 (57)	43 (57)	43 (57)	43 (57)	43 (57)	43 (57)
O Roll back at carry	degrees	44 (52)	44 (52)	44 (52)	44 (52)	44 (52)	44 (52)	44 (52)	44 (52)	44 (52)	44 (52)	44 (52)	44 (52)
P Roll back at ground level	degrees	41 (46)	41 (46)	41 (46)	41 (46)	41 (46)	41 (46)	41 (46)	41 (46)	41 (46)	41 (46)	41 (46)	41 (46)
Q Load over height	ft in (mm)	13' 1" (3999)	13' 1" (3999)	13' 3" (4031)	13' 3" (4031)	13' 1" (3999)	13' 1" (3999)	13' 1" (3999)	13' 1" (3999)	13' 3" (4031)	13' 3" (4031)	13' 1" (3999)	13' 1" (3999)
R Dump height (45 deg dump)	ft in (mm)	9' 7" (2923)	9' 5" (2881)	10' 1" (3072)	9' 11" (3030)	9' 7" (2923)	9' 5" (2881)	9' 3" (2817)	9' 1" (2775)	9' 9" (2966)	9' 7" (2924)	9' 3" (2817)	9' 1" (2772)
S Dig depth	in (mm)	5" (120)	5" (120)	3" (88)	3" (88)	5" (120)	5" (120)	5" (120)	5" (120)	3" (88)	3" (88)	5" (120)	5" (120)
T Reach at dump height	ft in (mm)	4' 4" (1326)	4' 6" (1368)	4' 0" (1216)	4' 2" (1258)	4' 4" (1326)	4' 6" (1368)	4' 8" (1432)	4' 10" (1474)	4' 4" (1322)	4' 6" (1364)	4' 8" (1432)	4' 10" (1474)
V Pin height	ft in (mm)	14' 2" (4307)	14' 2" (4307)	14' 2" (4307)	14' 2" (4307)	14' 2" (4307)	14' 2" (4307)	14' 2" (4307)	14' 2" (4307)	14' 2" (4307)	14' 2" (4307)	14' 2" (4307)	14' 2" (4307)
Reach maximum (45 deg dump) horizontal arm	ft in (mm)	7' 7" (2303)	7' 8" (2345)	7' 2" (2193)	7' 4" (2232)	7' 7" (2303)	7' 8" (2345)	7' 11" (2409)	8' 0" (2451)	7' 7" (2299)	8' 0" (2438)	7' 11" (2409)	8' 0" (2451)
Operating weight (includes 75kg operator and full fuel and DEF tanks)	lbs (kg)	44428 (20152)	44529 (20198)	44670 (20262)	44771 (20308)	44754 (20300)	44855 (20346)	44928 (20379)	45027 (20424)	45171 (20489)	45270 (20534)	45254 (20527)	45353 (20572)

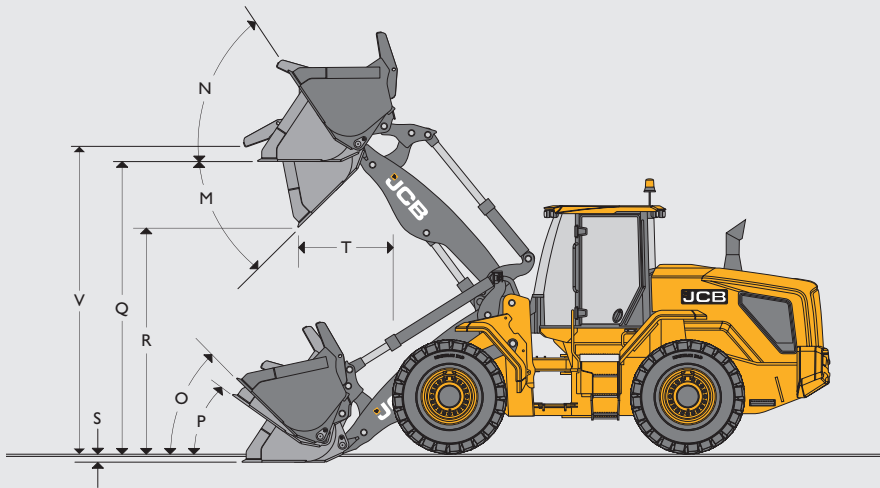

TIRE SIZE – 457 HT SHL

Tire size	Manufacturer	Type	Rating	Op weight lbs (kg)	HT SHL		Dimensions	
					STL lbs (kg)	FTTL lbs (kg)	Vertical in (mm)	Width ft-in (mm)
23.5R25 (radial)	Michelin	XTLA	L2	-26 (-12)	-13 (-6)	-11 (-5)	-0.1 (-2)	-0.1 (-3)
650/65R25 (radial)	Michelin	XLD	L3	-203 (-92)	-103 (-47)	-90 (-41)	-2.2 (-56)	1.4 (35)
23.5R25 (radial)	Goodyear	TL-3A+	L3	714 (324)	362 (164)	320 (145)	0.6 (16)	0.6 (16)
23.5R25 (radial)	Goodyear	RT-3B	L3	388 (176)	197 (89)	174 (79)	0.5 (12)	1.6 (41)
23.5R25 (Crossply)	Goodyear	HRL-3A (20PLY)	L3	-220 (-100)	-111 (-50)	-98 (-45)	0.9 (24)	0.9 (23)
23.5R25 (Crossply)	JCB	SITEMASTER (24PLY)	L3	-203 (-92)	-103 (-47)	-91 (-41)	0.2 (6)	0.0 (1)
23.5R25 (radial)	JCB	EARTHMOVER	L3	353 (160)	179 (81)	159 (72)	0.0 (1)	0.2 (6)
23.5R25 (radial)	Michelin	XLDD2A	L5	1208 (548)	613 (278)	542 (246)	1.1 (27)	0.5 (13)
23.5R25 (radial)	Michelin	XMINED2	L5	1825 (828)	927 (421)	819 (371)	1.5 (37)	1.5 (38)
23.5R25 (radial)	Goodyear	RL-5K	L5	1746 (792)	886 (402)	783 (355)	0.4 (9)	0.9 (24)
23.5-25 (solid cushion)*	SG Revolution	S2 C2 DWL	-	6887 (3124)	3496 (1586)	3087 (1400)	2.0 (51)	-0.9 (-24)
Heavy-duty counterweight	-	-	-	1706 (774)	2482 (1126)	2103 (954)	0.0 (0)	0.0 (0)

*Heavy duty counterweight replaced by standard counterweight when solid tires are fitted

LOADER DIMENSIONS – 457 HT SHL

Assumes machine is fitted with Michelin 23.5R25 XHA2 (L3) tires and heavy duty counterweight.

Model	457 HT SHL														
	Shovel mounting	Direct							Quickhitch						
		Shovel type	General purpose							General purpose					
Shovel equipment	Tipped teeth			Reversible toeplate		Tipped teeth and toeplate segments		Tipped teeth		Reversible toeplate		Tipped teeth and toeplate segments			
Shovel capacity (SAE heaped)	yd ³ (m ³)	3.7 (2.8)	4.1 (3.1)	4.3 (3.3)	4.3 (3.3)	4.6 (3.5)	4.3 (3.3)	4.6 (3.5)	4.1 (3.1)	4.3 (3.3)	4.3 (3.3)	4.6 (3.5)	4.3 (3.3)	4.6 (3.5)	
Shovel capacity (struck)	yd ³ (m ³)	2.9 (2.210)	3.3 (2.497)	3.5 (2.687)	3.5 (2.648)	3.7 (2.844)	3.5 (2.648)	3.7 (2.844)	3.3 (2.497)	3.5 (2.687)	3.5 (2.648)	3.7 (2.844)	3.5 (2.648)	3.7 (2.844)	
Shovel width	ft in (mm)	9' 4" (2837)	9' 4" (2837)	9' 4" (2837)	9' 2" (2800)	9' 2" (2800)	9' 4" (2837)	9' 4" (2837)	9' 4" (2837)	9' 4" (2837)	9' 2" (2800)	9' 2" (2800)	9' 4" (2837)	9' 4" (2837)	
Shovel weight	lbs (kg)	3190 (1447)	3349 (1519)	3450 (1565)	3591 (1629)	3693 (1675)	3675 (1667)	3777 (1713)	3144 (1426)	3124 (1417)	3386 (1536)	3486 (1581)	3470 (1574)	3569 (1619)	
Maximum material density *	lbs/ft ³ (kg/m ³)	100 (1609)	90 (1449)	84 (1351)	84 (1345)	79 (1258)	84 (1340)	78 (1253)	83 (1322)	77 (1232)	77 (1226)	72 (1146)	76 (1220)	71 (1140)	
Tipping load straight *	lbs (kg)	23963 (10870)	23934 (10856)	23766 (10780)	23695 (10748)	23527 (10672)	23613 (10711)	23445 (10634)	22486 (10199)	22323 (10126)	22247 (10091)	22084 (10017)	22165 (10054)	22002 (9980)	
Tipping load full turn *	lbs (kg)	19862 (9009)	19812 (8987)	19654 (8915)	19574 (8879)	19415 (8806)	19491 (8841)	19332 (8769)	18072 (8197)	17920 (8128)	17833 (8089)	17681 (8020)	17751 (8052)	17598 (7982)	
Payload *	lbs (kg)	9931 (4505)	9906 (4493)	9827 (4457)	9787 (4439)	9707 (4403)	9746 (4421)	9666 (4384)	9036 (4099)	8960 (4064)	8917 (4045)	8840 (4010)	8875 (4026)	8799 (3991)	
Maximum breakout force	lbf (kN)	39342 (175)	36644 (163)	34845 (155)	34171 (152)	32597 (145)	34171 (152)	32597 (145)	32822 (146)	31473 (140)	30799 (137)	29675 (132)	30799 (137)	29675 (132)	
M Dump angle maximum	degrees	50 (45)	50 (45)	50 (45)	50 (45)	50 (45)	50 (45)	50 (45)	50 (45)	50 (45)	50 (45)	50 (45)	50 (45)	50 (45)	
N Roll back angle full height	degrees	43 (58)	43 (58)	43 (58)	43 (58)	43 (58)	43 (58)	43 (58)	43 (58)	43 (58)	43 (58)	43 (58)	43 (58)	43 (58)	
O Roll back at carry	degrees	44 (54)	44 (54)	44 (54)	44 (54)	44 (54)	44 (54)	44 (54)	44 (54)	44 (54)	44 (54)	44 (54)	44 (54)	44 (54)	
P Roll back at ground level	degrees	41 (46)	41 (46)	41 (46)	41 (46)	41 (46)	41 (46)	41 (46)	41 (46)	41 (46)	41 (46)	41 (46)	41 (46)	41 (46)	
Q Load over height	ft in (mm)	16' 3" (4962)	16' 3" (4962)	16' 3" (4962)	16' 5" (4997)	16' 5" (4997)	16' 3" (4965)	16' 3" (4965)	16' 3" (4965)	16' 3" (4965)	16' 5" (4997)	16' 5" (4997)	16' 3" (4965)	16' 3" (4965)	
R Dump height (45 deg dump)	ft in (mm)	13' 0" (3953)	12' 9" (3889)	12' 7" (3847)	13' 3" (4037)	13' 1" (3996)	12' 9" (3889)	12' 7" (3847)	12' 5" (3783)	12' 3" (3741)	12' 11" (3932)	12' 9" (3890)	12' 5" (3783)	12' 3" (3741)	
S Dig depth	in (mm)	5" (120)	5" (120)	5" (120)	3" (88)	3" (88)	5" (120)	5" (120)	5" (120)	5" (120)	3" (88)	3" (88)	5" (120)	5" (120)	
T Reach at dump height	ft in (mm)	4' 4" (1319)	4' 6" (1383)	4' 8" (1425)	4' 2" (1273)	4' 4" (1315)	4' 6" (1383)	4' 8" (1425)	4' 11" (1489)	5' 0" (1531)	4' 6" (1379)	4' 8" (1421)	4' 11" (1489)	5' 0" (1531)	
V Pin height	ft in (mm)	17' 4" (5273)	17' 4" (5273)	17' 4" (5273)	17' 4" (5273)	17' 4" (5273)	17' 4" (5273)	17' 4" (5273)	17' 4" (5273)	17' 4" (5273)	17' 4" (5273)	17' 4" (5273)	17' 4" (5273)	17' 4" (5273)	
Reach maximum (45 deg dump) horizontal arm	ft in (mm)	10' 0" (3038)	10' 2" (3102)	10' 4" (3144)	9' 10" (2992)	9' 11" (3034)	10' 2" (3102)	10' 4" (3144)	10' 6" (3208)	10' 8" (3249)	10' 2" (3098)	10' 4" (3140)	10' 6" (3208)	10' 8" (3249)	
Operating weight (includes 75kg operator and full fuel and DEF tanks)	lbs (kg)	46273 (20989)	46432 (21061)	46533 (21107)	46674 (21171)	46775 (21217)	46758 (21209)	46859 (21255)	46932 (21288)	47031 (21333)	47175 (21398)	47274 (21443)	47258 (21436)	47357 (21481)	

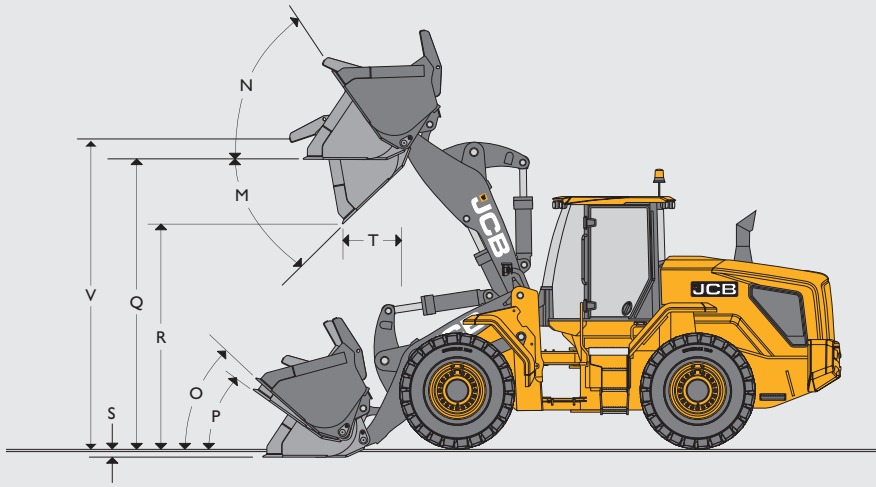

TIRE SIZE - 457 ZX					ZX			Dimensions	
Tire size	Manufacturer	Type	Rating	Op weight lbs (kg)	STL lbs (kg)	FTTL lbs (kg)	Vertical in (mm)	Width ft-in (mm)	
23.5R25 (radial)	Michelin	XTLA	L2	-26 (-12)	-20 (-9)	-18 (-8)	-0.1 (-2)	-0.1 (-3)	
650/65R25 (radial)	Michelin	XLD	L3	-203 (-92)	-159 (-72)	-139 (-63)	-2.2 (-56)	1.4 (35)	
23.5R25 (radial)	Goodyear	TL-3A+	L3	714 (324)	560 (254)	494 (224)	0.6 (16)	0.6 (16)	
23.5R25 (radial)	Goodyear	RT-3B	L3	388 (176)	304 (138)	269 (122)	0.5 (12)	1.6 (41)	
23.5R25 (Crossply)	Goodyear	HRL-3A (20PLY)	L3	-220 (-100)	-172 (-78)	-152 (-69)	0.9 (24)	0.9 (23)	
23.5R25 (Crossply)	JCB	SITEMASTER (24PLY)	L3	-203 (-92)	-159 (-72)	-141 (-64)	0.2 (6)	0.0 (1)	
23.5R25 (radial)	JCB	EARTHMOVER	L3	353 (160)	276 (125)	245 (111)	0.0 (1)	0.2 (6)	
23.5R25 (radial)	Michelin	XLDD2A	L5	1208 (548)	948 (430)	838 (380)	1.1 (27)	0.5 (13)	
23.5R25 (radial)	Michelin	XMINED2	L5	1825 (828)	1433 (650)	1265 (574)	1.5 (37)	1.5 (38)	
23.5R25 (radial)	Goodyear	RL-5K	L5	1746 (792)	1369 (621)	1210 (549)	0.4 (9)	0.9 (24)	
23.5-25 (solid cushion)*	SG Revolution	S2 C2 DWL	-	6887 (3124)	5404 (2451)	4771 (2164)	2.0 (51)	-0.9 (-24)	
Heavy duty counterweight	-	-	-	1706 (1740)	3836 (1740)	3250 (1474)	0.0 (0)	0.0 (0)	

*Heavy duty counterweight replaced by standard counterweight when solid tires are fitted

LOADER DIMENSIONS - 457 ZX

Assumes machine is fitted with Michelin 23.5R25 XHA2 (L3) tires and heavy duty counterweight.

Model	457 ZX												
	Shovel mounting	Direct						Quickhitch					
		Shovel type	General purpose						General purpose				
Shovel equipment	Tipped teeth		Reversible toeplate		Tipped teeth and toeplate segments		Tipped teeth		Reversible toeplate		Tipped teeth and toeplate segments		
Shovel capacity (SAE heaped)	yd ³ (m ³)	4.1 (3.1)	4.3 (3.3)	4.3 (3.3)	4.6 (3.5)	4.3 (3.3)	4.6 (3.5)	4.1 (3.1)	4.3 (3.3)	4.3 (3.3)	4.6 (3.5)	4.3 (3.3)	4.6 (3.5)
Shovel capacity (struck)	yd ³ (m ³)	3.7 (2.791)	3.9 (2.991)	3.8 (2.933)	4.1 (3.137)	3.8 (2.933)	4.1 (3.137)	3.3 (2.497)	3.5 (2.687)	3.5 (2.648)	3.7 (2.844)	3.5 (2.648)	3.7 (2.844)
Shovel width	ft in (mm)	9' 4" (2837)	9' 4" (2837)	9' 2" (2800)	9' 2" (2800)	9' 4" (2837)	9' 4" (2837)	9' 4" (2837)	9' 4" (2837)	9' 2" (2800)	9' 2" (2800)	9' 4" (2837)	9' 4" (2837)
Shovel weight	lbs (kg)	3556 (1613)	3651 (1656)	3799 (1723)	3893 (1766)	3882 (1761)	3977 (1804)	3144 (1426)	3243 (1471)	3386 (1536)	3486 (1581)	3470 (1574)	3569 (1619)
Maximum material density *	lbs/ft ³ (kg/m ³)	140 (2247)	131 (2096)	131 (2095)	122 (1961)	130 (2089)	122 (1956)	134 (2146)	125 (2007)	125 (1999)	117 (1877)	124 (1993)	117 (1871)
Tipping load straight *	lbs (kg)	36397 (16510)	36163 (16403)	36159 (16402)	35924 (16295)	36077 (16364)	35842 (16258)	34898 (15829)	34768 (15770)	34655 (15719)	34525 (15660)	34571 (15681)	34442 (15622)
Tipping load full turn *	lbs (kg)	30717 (13933)	30502 (13835)	30479 (13825)	30263 (13727)	30397 (13788)	30180 (13690)	29331 (13304)	29206 (13248)	29089 (13194)	28964 (13138)	29005 (13156)	28880 (13100)
Payload *	lbs (kg)	15359 (6967)	15251 (6918)	15239 (6913)	15131 (6864)	15198 (6894)	15090 (6845)	14666 (6652)	14603 (6624)	14544 (6597)	14482 (6569)	14502 (6578)	14440 (6550)
Maximum breakout force	lbf (kN)	38667 (172)	37093 (165)	36194 (161)	34621 (154)	36194 (161)	34621 (154)	34396 (153)	33047 (147)	32148 (143)	30799 (137)	32148 (143)	30799 (137)
M Dump angle maximum	degrees	50 (45)	50 (45)	50 (45)	50 (45)	50 (45)	50 (45)	50 (45)	50 (45)	50 (45)	50 (45)	50 (45)	50 (45)
N Roll back angle full height	degrees	43 (67)	43 (67)	43 (67)	43 (67)	43 (67)	43 (67)	43 (67)	43 (67)	43 (67)	43 (67)	43 (67)	43 (67)
O Roll back at carry	degrees	44 (45)	44 (45)	44 (45)	44 (45)	44 (45)	44 (45)	44 (45)	44 (45)	44 (45)	44 (45)	44 (45)	44 (45)
P Roll back at ground level	degrees	41 (39)	41 (39)	41 (39)	41 (39)	41 (39)	41 (39)	41 (39)	41 (39)	41 (39)	41 (39)	41 (39)	41 (39)
Q Load over height	ft in (mm)	12' 6" (3802)	12' 6" (3802)	12' 7" (3834)	12' 7" (3834)	12' 6" (3802)	12' 6" (3802)	12' 6" (3802)	12' 6" (3802)	12' 7" (3834)	12' 7" (3834)	12' 6" (3802)	12' 6" (3802)
R Dump height (45 deg dump)	ft in (mm)	9' 0" (2740)	8' 10" (2698)	9' 6" (2890)	9' 4" (2848)	9' 0" (2740)	8' 10" (2698)	8' 7" (2620)	8' 5" (2578)	9' 1" (2770)	8' 11" (2728)	8' 7" (2620)	8' 5" (2578)
S Dig depth	in (mm)	5" (120)	5" (120)	3" (88)	3" (88)	5" (120)	5" (120)	5" (120)	5" (120)	3" (88)	3" (88)	5" (120)	5" (120)
T Reach at dump height	ft in (mm)	4' 3" (1301)	4' 5" (1343)	3' 11" (1191)	4' 1" (1233)	4' 3" (1301)	4' 5" (1343)	4' 8" (1421)	4' 10" (1463)	4' 4" (1311)	4' 5" (1353)	4' 8" (1421)	4' 10" (1463)
V Pin height	ft in (mm)	13' 6" (4110)	13' 6" (4110)	13' 6" (4110)	13' 6" (4110)	13' 6" (4110)	13' 6" (4110)	13' 6" (4110)	13' 6" (4110)	13' 6" (4110)	13' 6" (4110)	13' 6" (4110)	13' 6" (4110)
Reach maximum (45 deg dump) horizontal arm	ft in (mm)	7' 0" (2140)	7' 2" (2182)	6' 8" (2029)	6' 10" (2071)	7' 0" (2140)	7' 2" (2182)	7' 5" (2260)	7' 7" (2302)	7' 1" (2149)	7' 2" (2191)	7' 5" (2260)	7' 7" (2302)
Operating weight (includes 75kg operator and full fuel and DEF tanks)	lbs (kg)	43257 (19621)	43352 (19664)	43499 (17931)	43594 (19774)	43583 (19769)	43678 (19812)	44057 (19984)	44156 (20029)	44300 (20094)	44399 (20139)	44383 (20132)	44483 (20177)

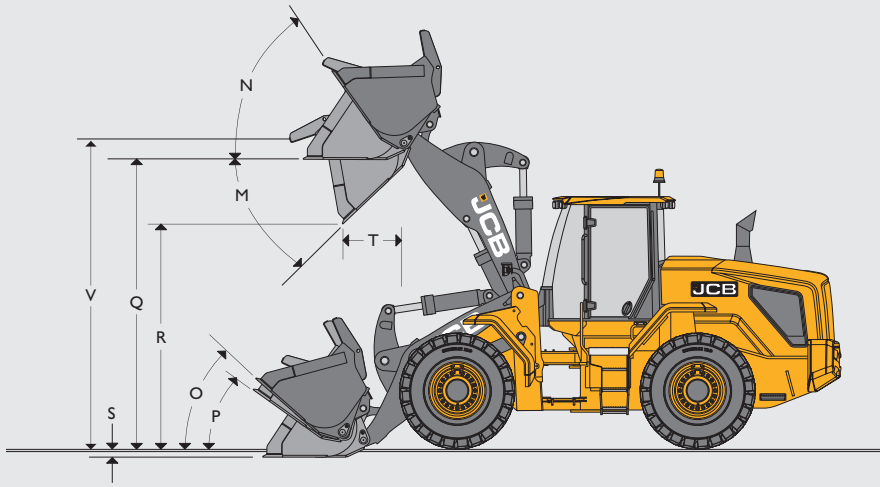

TIRE SIZE – 457 ZX HL

Tire size	Manufacturer	Type	Rating	Op weight lbs (kg)	ZX HL		Dimensions	
					STL lbs (kg)	FTTL lbs (kg)	Vertical in (mm)	Width ft-in (mm)
23.5R25 (radial)	Michelin	XTLA	L2	-26 (-12)	-16 (-7)	-14 (-6)	-0.1 (-2)	-0.1 (-3)
650/65R25 (radial)	Michelin	XLD	L3	-203 (-92)	-125 (-57)	-110 (-50)	-2.2 (-56)	1.4 (35)
23.5R25 (radial)	Goodyear	TL-3A+	L3	714 (324)	442 (200)	390 (177)	0.6 (16)	0.6 (16)
23.5R25 (radial)	Goodyear	RT-3B	L3	388 (176)	240 (109)	212 (96)	0.5 (12)	1.6 (41)
23.5R25 (Crossply)	Goodyear	HRL-3A (20PLY)	L3	-220 (-100)	-136 (-62)	-120 (-54)	0.9 (24)	0.9 (23)
23.5R25 (Crossply)	JCB	SITEMASTER (24PLY)	L3	-203 (-92)	-125 (-57)	-111 (-50)	0.2 (6)	0.0 (1)
23.5R25 (radial)	JCB	EARTHMOVER	L3	353 (160)	218 (99)	192 (87)	0.0 (1)	0.2 (6)
23.5R25 (radial)	Michelin	XLDD2A	L5	1208 (548)	748 (339)	661 (300)	1.1 (27)	0.5 (13)
23.5R25 (radial)	Michelin	XMINED2	L5	1825 (828)	1131 (513)	998 (453)	1.5 (37)	1.5 (38)
23.5R25 (radial)	Goodyear	RL-5K	L5	1746 (792)	1080 (490)	955 (433)	0.4 (9)	0.9 (24)
23.5-25 (solid cushion)*	SG Revolution	S2 C2 DWL	-	6887 (3124)	4263 (1934)	3764 (1707)	2.0 (51)	-0.9 (-24)
Heavy duty counterweight	-	-	-	1706 (1740)	3027 (1373)	2564 (1163)	0.0 (0)	0.0 (0)

*Heavy duty counterweight replaced by standard counterweight when solid tires are fitted

LOADER DIMENSIONS – 457 ZX HL

Assumes machine is fitted with Michelin 23.5R25 XHA2 (L3) tires and heavy duty counterweight.

Model	457 ZX HL														
	Shovel mounting	Direct							Quickhitch						
		Shovel type	General purpose							General purpose					
Shovel equipment	Tipped teeth			Reversible toeplate		Tipped teeth and toeplate segments		Tipped teeth		Reversible toeplate		Tipped teeth and toeplate segments			
Shovel capacity (SAE heaped)	yd ³ (m ³)	3.7 (2.8)	4.1 (3.1)	4.3 (3.3)	4.3 (3.3)	4.6 (3.5)	4.3 (3.3)	4.6 (3.5)	4.1 (3.1)	4.3 (3.3)	4.3 (3.3)	4.6 (3.5)	4.3 (3.3)	4.6 (3.5)	
Shovel capacity (struck)	yd ³ (m ³)	3.3 (2.497)	3.7 (2.791)	3.9 (2.991)	3.8 (2.933)	4.1 (3.137)	3.8 (2.933)	4.1 (3.137)	3.3 (2.497)	3.5 (2.687)	3.5 (2.648)	3.7 (2.844)	3.6 (2.648)	3.7 (2.844)	
Shovel width	ft in (mm)	9' 4" (2837)	9' 4" (2837)	9' 4" (2837)	9' 2" (2800)	9' 2" (2800)	9' 4" (2837)	9' 4" (2837)	9' 4" (2837)	9' 4" (2837)	9' 2" (2800)	9' 2" (2800)	9' 4" (2837)	9' 4" (2837)	
Shovel weight	lbs (kg)	3395 (1540)	3556 (1613)	3651 (1656)	3799 (1723)	3893 (1766)	3882 (1761)	3977 (1804)	3144 (1426)	3243 (1471)	3386 (1536)	3486 (1581)	3470 (1574)	3569 (1619)	
Maximum material density *	lbs/ft (kg/m ³)	117 (1876)	104 (1672)	97 (1556)	97 (1554)	91 (1452)	97 (1549)	90 (1447)	99 (1593)	93 (1487)	92 (1482)	87 (1388)	92 (1476)	86 (1383)	
Tipping load straight *	lbs (kg)	27660 (12546)	27326 (12395)	27101 (12293)	27089 (12287)	26864 (12185)	27007 (12250)	26782 (12148)	26153 (11863)	26004 (11795)	25931 (11762)	25782 (11695)	25855 (11728)	25706 (11660)	
Tipping load full turn *	lbs (kg)	23159 (10505)	22850 (10365)	22644 (10271)	22613 (10257)	22407 (10163)	22532 (10220)	22325 (10126)	21780 (9879)	21639 (9815)	21559 (9779)	21418 (9715)	21483 (9744)	21341 (9680)	
Payload *	lbs (kg)	11579 (5252)	11425 (5182)	11322 (5135)	11307 (5129)	11203 (5082)	11266 (5110)	11162 (5063)	10890 (4940)	10820 (4908)	10779 (4889)	10709 (4857)	10741 (4872)	10671 (4840)	
Maximum breakout force	lbf (kN)	36869 (164)	33946 (151)	32597 (145)	31923 (142)	30574 (136)	31923 (142)	30574 (136)	30124 (134)	29000 (129)	28326 (126)	27202 (121)	28326 (126)	27202 (121)	
M Dump angle maximum	degrees	50 (45)	50 (45)	50 (45)	50 (45)	50 (45)	50 (45)	50 (45)	50 (45)	50 (45)	50 (45)	50 (45)	50 (45)	50 (45)	
N Roll back angle full height	degrees	43 (53)	43 (53)	43 (53)	43 (53)	43 (53)	43 (53)	43 (53)	43 (53)	43 (53)	43 (53)	43 (53)	43 (53)	43 (53)	
O Roll back at carry	degrees	44 (52)	44 (52)	44 (52)	44 (52)	44 (52)	44 (52)	44 (52)	44 (52)	44 (52)	44 (52)	44 (52)	44 (52)	44 (52)	
P Roll back at ground level	degrees	41 (44)	41 (44)	41 (44)	41 (44)	41 (44)	41 (44)	41 (44)	41 (44)	41 (44)	41 (44)	41 (44)	41 (44)	41 (44)	
Q Load over height	ft in (mm)	14' 4" (4373)	14' 4" (4373)	14' 4" (4373)	14' 5" (4405)	14' 5" (4405)	14' 4" (4373)	14' 4" (4373)	14' 4" (4373)	14' 4" (4373)	14' 5" (4405)	14' 1" (4285)	14' 4" (4373)	14' 4" (4373)	
R Dump height (45 deg dump)	ft in (mm)	11' 1" (3374)	10' 10" (3310)	10' 9" (3268)	11' 4" (3460)	11' 3" (3418)	10' 10" (3310)	10' 9" (3268)	10' 6" (3190)	10' 4" (3148)	10' 11" (3340)	10' 10" (3298)	10' 6" (3190)	10' 4" (3148)	
S Dig depth	in (mm)	6" (164)	6" (164)	6" (164)	5" (132)	5" (132)	6" (164)	6" (164)	6" (164)	6" (164)	5" (132)	5" (132)	6" (164)	6" (164)	
T Reach at dump height	ft in (mm)	4' 4" (1315)	4' 6" (1379)	4' 8" (1421)	4' 2" (1269)	4' 4" (1311)	4' 6" (1379)	4' 8" (1421)	4' 11" (1499)	5' 1" (1541)	4' 7" (1389)	4' 8" (1431)	4' 11" (1499)	5' 1" (1541)	
V Pin height	ft in (mm)	15' 4" (4680)	15' 4" (4680)	15' 4" (4680)	15' 4" (4680)	15' 4" (4680)	15' 4" (4680)	15' 4" (4680)	15' 4" (4680)	15' 4" (4680)	15' 4" (4680)	15' 4" (4680)	15' 4" (4680)	15' 4" (4680)	
Reach maximum (45 deg dump) horizontal arm	ft in (mm)	8' 8" (2553)	8' 7" (2617)	8' 9" (2659)	8' 3" (2507)	8' 4" (2549)	8' 7" (2617)	8' 9" (2659)	9' 0" (2737)	9' 1" (2779)	8' 7" (2627)	8' 9" (2669)	9' 0" (2737)	9' 1" (2779)	
Operating weight (includes 75kg operator and full fuel and DEF tanks)	lbs (kg)	43835 (19883)	43995 (19956)	44090 (19999)	44238 (20066)	44333 (20109)	44322 (20104)	44417 (20147)	44796 (20319)	44895 (20364)	45038 (20429)	45137 (20474)	45122 (20467)	45221 (20512)	

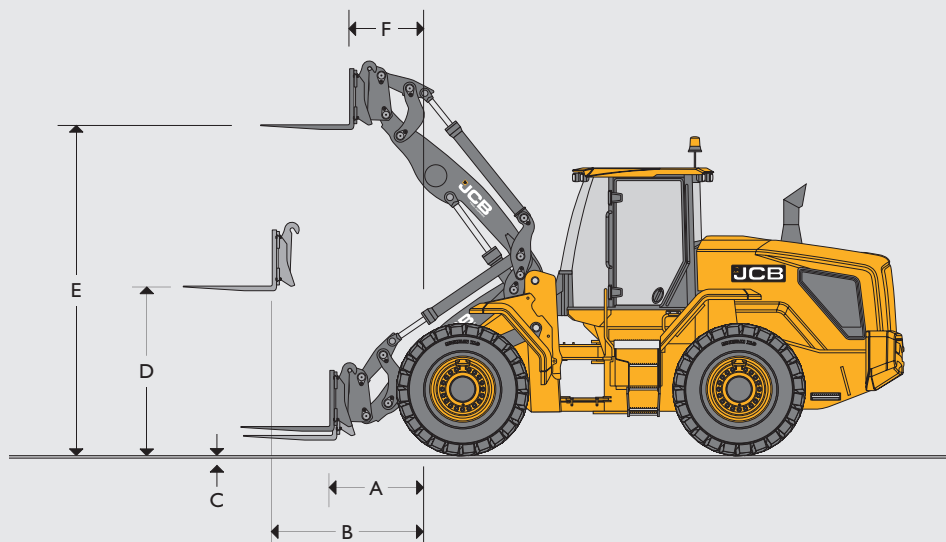

LOADER DIMENSIONS WITH FORKS

		457 HT	457 HT SHL	457 ZX	457 ZX SHL
Fork carriage width	ft-in (mm)	4' 11" (1500)	4' 11" (1500)	4' 11" (1500)	4' 11" (1500)
Length of tines	ft-in (mm)	4' 0" (1220)	4' 0" (1220)	4' 0" (1220)	4' 0" (1220)
A Reach at ground level	ft-in (mm)	3' 10" (1173)	7' 0" (2140)	3' 3" (978)	5' 1" (1550)
B Reach at arms horizontal	ft-in (mm)	6' 1" (1848)	8' 8" (2648)	5' 7" (1698)	7' 2" (2175)
C Top of tine above ground with arms down	in (mm)	1" (35)	1" (35)	1" (35)	1" (35)
D Arms, horizontal height	ft-in (mm)	6' 4" (1935)	6' 4" (1935)	6' 4" (1935)	6' 4" (1935)
E Arms, maximum height	ft-in (mm)	13' 8" (4154)	16' 10" (5120)	13' 0" (3957)	14' 10" (4528)
F Reach at maximum height	ft-in (mm)	2' 10" (871)	3' 1" (929)	2' 10" (860)	3' 1" (938)
Tipping load straight	lbs (kg)	26951 (12225)	19942 (9045)	25116 (11392)	21070 (9557)
Tipping load full turn (40°)	lbs (kg)	22873 (10375)	16281 (7385)	21267 (9647)	17735 (8044)
Payload*	lbs (kg)	17637 (8000)	13025 (5908)	17014 (7717)	14188 (6435)
Attachment weight	lbs (kg)	1345 (610)	1345 (610)	1345 (610)	1345 (610)
Operating weight (includes 75kg operator and full fuel and DEF tanks)	lbs (kg)	43129 (19563)	45133 (20472)	42258 (19168)	42997 (19503)

* At the centre of gravity distance 2ft (600mm). Based on 80% of FTTL as defined in ISO 8313. Manual fork spacing's at 2" (50mm) increments. Class 4A forks (section 6" (150mm) x 2.3" (60mm)). HT machines have parallel lift loader end. ZX machines do not. HT machines have heavy duty counterweight

SERVICE FILL CAPACITIES

Hydraulic system	gallons (liters)	63.4 (240)
Hydraulic tank	gallons (liters)	35.7 (135)
Fuel tank	gallons (liters)	79.3 (300)
Engine oil including filter	gallons (liters)	6.6 (25)
Transmission oil system	gallons (liters)	10.8 (41) / 11.9 (45) with open diff axles
Axle oil (front)	gallons (liters)	9.2 (35)
Axle oil (rear)	gallons (liters)	9.2 (35)
Engine coolant system	gallons (liters)	11.1 (42)
DEF tank	gallons (liters)	11.1 (42)

MATERIAL DENSITY

Material	Loose density lb/yd ³ (kg/m ³)	Fill factor %	Material	Loose density lb/yd ³ (kg/m ³)	Fill factor %
Snow (fresh)	340 (200)	110	Sodium chloride (dry) (salt)	2190 (1300)	85
Peat (dry)	670 (400)	100	Cement portland	2430 (1440)	100
Sugar beet	890 (530)	100	Limestone (crushed)	2580 (1530)	100
Coke (loose)	960 (570)	85	Sand (dry)	2610 (1550)	100
Barley	1010 (600)	85	Asphalt	2700 (1600)	100
Petroleum coke	1150 (680)	85	Gravel (dry)	2780 (1650)	85
Wheat	1230 (730)	85	Clay (wet)	2830 (1680)	110
Coal bitumous	1290 (765)	100	Sand (wet)	3190 (1890)	110
Fertiliser (mixed)	1740 (1030)	85	Fire clay	3510 (2080)	100
Coal anthracite	1760 (1046)	100	Copper (concentrate)	3880 (2300)	85
Earth (dry) (loose)	1940 (1150)	100	Slate	4720 (2800)	100
Nitrate fertiliser	2110 (1250)	85	Magnetite	5400 (3204)	100

BUCKET CAPACITIES

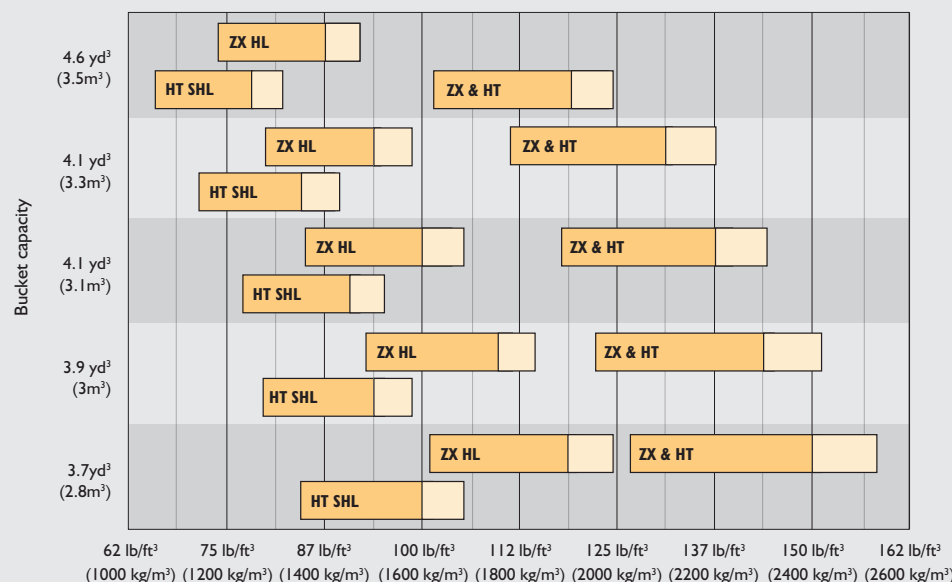

HT = Standard height arm HL = High Lift arm SHL = Super high lift arm ZX = Z bar

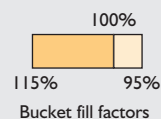

EQUIPMENT

SERVICE AND MAINTENANCE

3 year Livelink telematics	•
Engine oil remote drain and fill	•
Grouped pressure test points	•
Lockable tool box	•
Lubrication points accessible from ground level	•

ENGINE

Air cleaner – cyclonic pre filter with engine fan scavenge system	•
Automatically reversing cooling fan	+
Crankcase breather oil trap	•
DEF fluid	•
Electrical opening rear hood	•
Epoxy coated radiator / coolers	+
Fixed mounted fan	•
Fuel filter	•
Fuel pre-filter with water trap	•
Hydraulically driven cooling fan	•
Manual override rear bonnet opening	•
-4°F (-20°C) cold start	•
SCR engine emission control	•
Swing out fan	+
Waste gated turbo	•
Widecore radiator	+

ELECTRICAL

100 amp alternator	•
Amber rotating beacon	•
Electrical adjustable mirrors	•
Heated mirrors	•
External battery isolator	•
Fold down beacon arm	•
Green seat belt beacon	+
Halogen front and rear working lights	•
Hazard warning lights	•
Integrated rear view camera	+
LED front and rear working lights	+
Number plate light kit	+
Parking lights	•
Radio wiring and speakers	•
Rear fog light	•
Reverse alarm and light	•
Smart reverse alarm and light	+
Turn signals	•

ELECTRICAL (CONTINUED)

White noise reverse alarm and light	+
Work lights in rear grille	•
Hood operation alarm	•
Blue led reverse lights	+

DRIVE TRAIN

4 speed transmission	•
5 speed transmission with lock-up torque converter	+
Epicyclical wheel hub reduction	•
Fixed front axle	•
Gear kick down on loader control lever	•
Indicator glass for transmission oil level	•
Limited slip differentials front and rear	+
Loader lever direction control	•
Neutral start	•
Open differential	•
Open differential with automatic locking -100% (front axle only)	+
Oscillating rear axle	•
Power-inch intelligent clutch cut off on footbrake (selectable)	•
Selectable automatic power shift	•
Speed limiter 12 mph (20kph)	+
Steering column single lever shift control (direction and gear)	•
Transmission cooler bypass	+

BRAKE SYSTEM

Multi-plate wet disc brakes	•
Sintered brake pads	•
Dual circuit hydraulic power	•
Wheel speed braking	•
Parking disc brake on transmission output shaft	•
Electrical hydraulic park brake actuation	•

OPERATOR STATION

Fully glazed cab	•
Front low windshield guards	+
Air conditioning	•
Climate control	+
Single lever joystick	•
Multi-lever hydraulic controls	+
Proportional electro hydraulic auxiliary control	+
Air suspension cloth seat	•
Deluxe heated air suspension cloth seat	+
Super deluxe heated and cooled air suspension half leather seat	+
Front roller blind	•
Rear roller blind	+

OPERATOR STATION (CONTINUED)

Cab air intake filter	•
Carbon cab air intake filter	+
12V in cab power socket	•
2 x 12V in cab power socket	+
24V in cab power socket	+
Reversing camera (colour)	+
Fold away adjustable steering column	•
ROPS/FOPS safety structure	•
Interior light	•
Front primary display screen	•
Secondary A post display screen, rotary control menu interface	+
A post mounted membrane switches	•
Variable fan speed control on climatic control system	+
2" (50 mm) seat belt	•
3" (75mm) seat belt	+
Two speed intermittent front windshield wipe/wash and self-park	•
Single speed rear screen wipe/wash and self-park	•
3 speed heater/demisting	•
Lh and Rh sliding opening windows	•
Floor mat	•
Cup holder	•
Steering wheel spinner knob	•
Internal rear view mirror	•
Tinted cab glass	•
Multi-media port (USB and 3.5mm)	+
Operator stowage	•
Laminated windshield	•
Heated rear screen	•
Loader control isolator	•
Horn	•
Adjustable armrest	•
Removable storage rubber mats	•
Convex mirror kit (1 on each side)	+
Adjustable seat mounted controls	•

FRONT PRIMARY DISPLAY

Warning lights	
Direction indicators	•
Master warning	•
High coolant temperature	•
Battery charging condition	•
Low fuel level	•
Engine oil pressure	•
Hazard lamps	•

EQUIPMENT (CONTINUED)

FRONT PRIMARY DISPLAY

Warning lights (continued)	
Park brake state	•
Road lights	•
Main beam lights	•
Rear fog lights	•
Engine pre-heat	•
Brake system pressure	•
Differential lock	•
Low steering pressure	•
Buzzer alerts	
Engine air filter blocked	•
Diesel exhaust fluid (DEF)	•
Torque reduction in case of malfunction	•
Amber warning lamp	•
Stop engine	•
Gauge display	
Engine speed	•
Coolant temperature	•
Fuel level	•
LCD screen display	
Current gear	•
Stop engine	•
Torque reduction in case of malfunction	•
Amber warning lamp	•
Diesel exhaust fluid (DEF)	•
Engine air filter blocked	•
Secondary steer system pressure	•
Torque lockup	•
Steer mode	•
Ground speed	•
Engine Speed (numeric display)	•
Clock	•
Hydraulic state	•
Smoothride system (SRS)	+
Beacon	•
Front work lamps	•
Rear work lamps	•
Heated rear screen	•
Transmission sump temperature	•
Data screens	
DEF level	•
Hydraulic oil temperature	•
Torque convertor temperature	•
Volume of fuel remaining	•
Total fuel used (resettable)	•

FRONT PRIMARY DISPLAY (CONTINUED)

Data screens (continued)	
Instantaneous fuel use	•
Average fuel use (resettable)	•
Current date	•
Machine hours	•
Trip distance (resettable)	•
Hours to Service	•
Daily checks	
Engine oil level	•
DEF level	•
RIGHT HAND SECONDARY DISPLAY (OPTIONAL)	
Clock	•
Climate control	•
Fan speed	•
In cab temperature set	•
Machine hours	•
Rear view camera	•
Fuel use	•
Time and date	•
Auxiliary flow rate	+
Hydraulic oil temperature	•
Transmission oil temperature	•
Machine settings screen	
Coolant temperature	•
Engine oil pressure	•
Air filter	•
Transmission sump temperature	•
Transmission torque convertor temperature	•
Hydraulic oil temperature	•
Park brake pressure	•
Battery voltage	•
Help display	•
On-screen Handbook	•
HYDRAULIC SYSTEM	
Smoothride system (SRS)	+
Hydraulic quick hitch with in cab isolation	+
Auxiliary ARV kit	+
Auxiliary hydraulic service	+
Twin auxiliary hydraulic service	+
Twin piston pumps with priority steer	•
Emergency steer back-up	•
JCB biodegradable hydraulic oil	+

HYDRAULIC SYSTEM (CONTINUED)

Electronic hydraulic isolation	•
Automatic boom kick-out. Detent	•
Automatic bucket positioner	•
Front loader float	•
Indicator glass for hydraulic oil level	•
Hydraulic oil cooler	•
EXTERNAL EQUIPMENT	
Front and rear fenders	•
Full rear fenders	+
Front adjustable mud flaps	•
Front wheel spray guards	•
Rear fender chevrons	•
Full tire coverage fenders	•
Automatic greasing system	+
Grease gun and cartridge	+
One piece electrical opening hood	•
Mesh air intake screens	•
Flexible bottom step	•
Full width rear counterweight	•
Recovery hitch	•
Lifting / tie down lugs	•
Rear counterweight chevrons	+
Additional rear counterweight (+ 1706 lb (+774kg))	+
PROTECTIVE EQUIPMENT	
Front cab screen guards	+
Wastemaster package: includes front and rear light guards, front screen guard, front and rear belly guards, rear light guards, widerecore radiator, Wastemaster decal.	+
Rear grille guard	+
Fire system	+
Safety strut loader arm	•
Light guards	+
Front belly guard kits	+
Rear belly guard kits	+
Articulation joint safety strut	•
Front rubber apron mat	+
OTHER EQUIPMENT	
High lift loader end (ZX loader only)	+
Super high lift loader end (HT loader only)	+

STANDARD •

OPTIONAL +







ONE COMPANY, OVER 300 MACHINES.

Your nearest JCB Dealer

JCB North American – Headquarters

Savannah, 2000 Bamford Blvd., Savannah, Georgia, 31322 Tel: (912) 447-2000

Download the very latest information on this product range at www.jcb.com

JCB inc. All rights reserved. No part of this publication may be reproduced, stored in a retrieval system, or transmitted in any form or by any other means, electronic, mechanical, photocopying or otherwise, without prior permission from JCB inc. All references in this publication to operating weights, sizes, capacities and other performance measurements are provided for guidance only and may vary dependant upon the exact specification of machine. They should not therefore be relied upon in relation to suitability for a particular application. Guidance and advice should always be sought from your JCB Dealer. JCB reserves the right to change specifications without notice. Illustrations and specifications shown may include optional equipment and accessories. The JCB logo is a registered trademark of J C Bamford Excavators Ltd.

